

Mounting Instructions

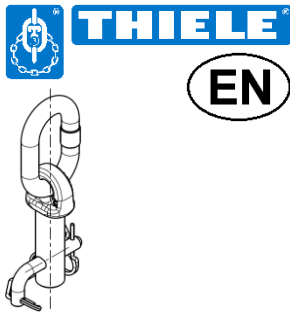

Lashing Point plug-in type TWN 1474

Manufacturer:
THIELE GmbH & Co. KG
Tel: +49 (0) 2371 / 947 - 0
58640 Iserlohn
www.thiele.de

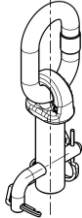

1 Description and Intended Use

Lashing Points plug-in type according to TWN 1474 serve for lashing on loading platforms of trucks (TWN = THIELE standard). They are intended for a temporarily use in combination with integrated bushing on loading platforms.

Lashing Points consist of forged pivots with welded-on intermediate links, in loading platform integrated bushing as well as safety systems made of pins and spring cotters. Pins and spring cotters assembled by chain links to units.

Assembly is made by moving the pivot into the bushing from above and securing the position by a pin form underneath the loading platform.

After that the pin is secured by a spring cotter.

In case of disuse the Lashing Point is to be assembled from underneath the loading platform so that the end of the pivot closes the bushing and enables a closed loading platform.

Lashing Points can be loaded to 100 % in all tensile directions. The pivot heads are marked with the maximum Lashing Capacity LC in daN (Deka-Newton) the manufacturers mark and a traceability code.

All parts from THIELE are galvanized.

The Lashing Points feature a safety factor of at least 2 based on the maximum Lashing Capacity.

Usage for lifting is not permissible!

Lashing Points must exclusively be used

- within the limits of their permissible Lashing Capacity,
- within the temperature limits prescribed,
- with properly bushing and welding.

2 Safety Notes

Risk of Injury!
Make sure to use lashing means free from defects.

- Operators, fitters and maintenance personnel must in particular observe this Instructions also from the used lashing chain assemblies, documentation DGUV V 1 issued by the German Employers' Liability Insurance Association as well as the Operating Instructions of the vehicle.
- Outside the Federal Republic of Germany the specific provisions issued locally in the country where the items are used must also be observed.
- The directions given in these Operating Instructions and specified documentations relating to safety, assembly, operation, inspection and maintenance must be made available to the respective persons.
- Make sure these instructions are available in a place near the product during the time the equipment is used. Please contact the manufacturer if replacements are needed.
- When performing work make sure to wear your personal protective equipment!
- **Improper assembly and use may cause personal injury and/or damage to property.**
- Assembly and removal as well as inspection and maintenance must exclusively be carried out by skilled and authorized persons.
- Structural changes are impermissible (e.g. welding, bending).
- Visually inspect the equipment prior to each use.
- Never put to use worn-out, bent or damaged Lashing Points.
- Do not exceed the specified Lashing Capacity.
- Do not use force when mounting/positioning the Lashing Points.
- Do not bend the intermediate links.
- Only remove lashing means manually (use your hands).

THIELE will not be responsible for damage caused through non-observance of instructions, rules, standards and notes indicated!

In the event of doubts about the use, inspection, maintenance or similar things contact your safety officer or the manufacturer!

Transportation of persons is forbidden!

3 Commissioning

Prior to using the components for the first time make sure that

- Lashing Points comply with the order and have not been damaged,
- test certificate and Mounting Instructions are at hand,
- markings correspond with what is specified in the documentation,
- documentation is safely kept in an orderly manner.

Dispose of the packing in an environmentally compatible way according to local rules.

4 Technical Data

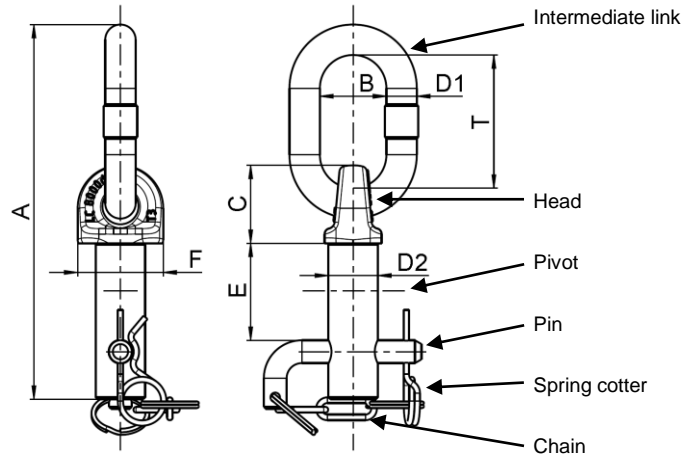

Lashing capacity LC [daN]	Article-no.	Dimensions [mm]								Mass [kg]
		A	B	C	D1	D2	E	F	T	
8.000	F352255	197	35	41	16	26	51	45	70	1,0

Installation situation and initial dimensions for bushing:

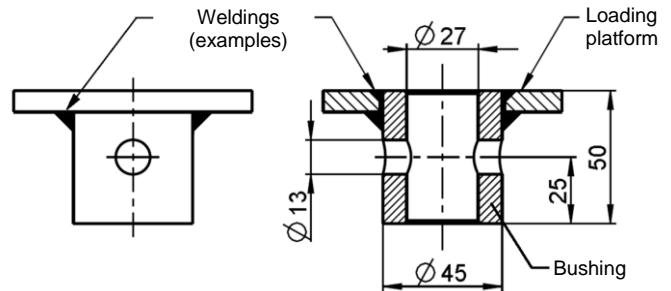

The bushing has to be made of material of minimum quality S355J2G3.

THIELE is not responsible for the selection of the material or further dimensions of bushing or surrounding design or their connecting to each other!

5 Mounting

5.1 Preparations

Make sure the mounting place is able to absorb the maximum specified Lashing Capacity multiplied with a safety factor of 1,25 without safety reducing deformation.

Take care for enough space for the resting position underneath the loading platform.

The mounting location for each Lashing Point has to ensure that

- no areas of danger are created (crushing point, shearing point),
- transportation is not restrained by overhang,
- used lashing means (e.g. hooks) are freely movable and will not be bended,
- lashing accessories will not be bypassed,
- incorrect use is avoided,
- Lashing Points cannot be damaged,
- Lashing Points can be used easily.

5.2 Welding Instructions

The following general Welding Instructions shall be duly followed:

Personell, Quality	DIN EN ISO 3834 DIN EN ISO 14731 DIN EN ISO 9606
Welding process	DIN EN 1011 DIN EN 1090 DIN EN 15085
Further	DIN 15018 ISO/TR 15608 SEW 088

Welding on pivot or intermediate link is not allowed!

6 Conditions of Use

6.1 Using position

Following charts show the using position. The position of the intermediate link may vary due to different tensile directions.

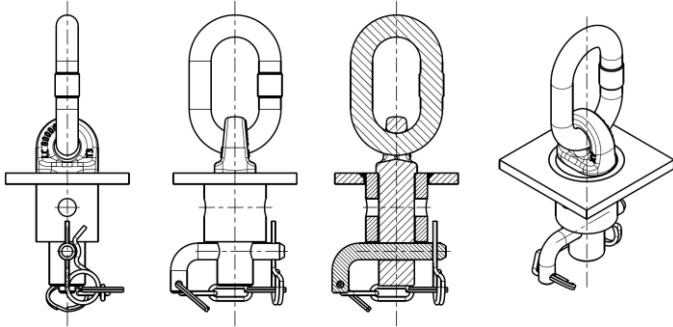

Mounting of using position:

1. Move pivot end into the bushing until the head is in contact with the front side of the bushing.
2. Move pin with its longer leg into cross-hole of pivot from underneath the loading platform.
3. Move spring cotter with its straight leg into the cross-hole of the pin until the crumpled leg surrounds the pin.

Dismounting of using position:

1. Unload the intermediate link and remove lashing means.
2. Remove spring cotter by pulling.
3. Remove pin by pulling.
4. Remove intermediate link and pivot upwards longitudinal to the centre of bushing.

6.2 Resting Position

Following charts show the resting position.

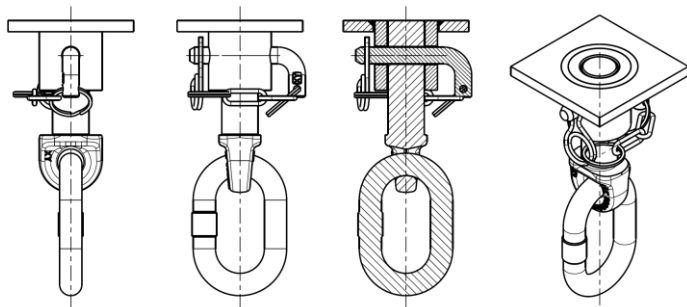

Mounting of resting position:

1. Move end of pivot into bushing from underneath the loading platform upwards and turn it until both cross-holes of bushing and pivot are in line.
2. Move pin with its longer leg into the cross-holes.
3. Move spring cotter with its straight leg into the cross-hole of the pin until the crumpled leg surrounds the pin.
You may have to turn the pin so that the legs of the spring cotter do not touch the bottom side of the loading platform or other parts.

Dismounting of resting position:

1. Remove spring cotter by pulling.
2. Remove pin by pulling.
Attention! Keep hold of intermediate link and pivot so that they do not fall down unintended due to gravity.
3. Remove intermediate link and pivot downwards longitudinal to the centre of bushing.

6.3 Normal Use

The intermediate link is intended to be assembled together with series lashing means for example hooks or shackles.

The intermediate link must always be freely movable. It must not rest on or be supported by other structural parts.

6.4 Influence of Temperature

The temperature range for use is -20 °C to +200 °C.

If the Lashing Points have been exposed to temperatures exceeding the maximum values specified they must no longer be used.

6.5 Environmental Influence

Lashing Points must not be used in environments where acids, aggressive or corrosive chemicals or their fumes are present.

Hot-dip galvanizing or a galvanic treatment is prohibited.

7 Inspections, Maintenance, Disposal

Inspections and maintenance must be arranged for by the Owner!

Inspection intervals shall be determined by the Owner!

Inspections must be carried out and documented by competent persons regularly but at least once a year or more frequently if the Lashing Points are in heavy-duty service.

After three years at the latest they must additionally be examined for cracks.

A load test shall never be considered a substitute for this examination.

The results of the inspection shall be entered into a register (DGUV I 209-062 or DGUV I 209-063) to be prepared at first use. The register will show characteristic data of the Lashing Points as well as identity details.

Immediately stop using Lashing Points that show the following defects:

- missing or illegible identification/markings,
- deformation, fractures, cuts, notches,
- limited articulation,
- heating beyond permissible limits,
- severe corrosion,
- wear exceeding 10 %, for example in the cross section of the intermediate link, the area of the head or at the diameter of the pin,
- weld failures.

Inspection Service

THIELE offers inspection, maintenance and repair services by trained and competent personnel.

Maintenance

Maintenance and repair work must only be performed by competent persons.

Minor notches and cracks at the intermediate link may be eliminated by careful grinding observing the maximum cross section reduction requirement of 10 % and avoid making more severe cuts or scores.

All maintenance and repair activities are to be documented.

Spare Parts

Pin completed by spring cotter and the other components, article-no. F352256. Spring cotter according to DIN 11024, size 3,2 A4-70.

Disposal

All components and accessories of steel taken out of service are to be scrapped in line with local regulations and provisions.

8 Storage

Lashing Points are stored in dry locations at temperatures ranging between 0 °C and +40 °C.

9 Publishing Informations

THIELE GmbH & Co. KG, Werkstraße 3, 58640 Iserlohn, Germany
Tel.: +49(0)2371/947-0 // Email: info@thiele.de

© THIELE GmbH & Co. KG, 2015. All rights reserved.

„#“ Changes to previous edition.