

1 DESCRIPTION AND INTENDED USE

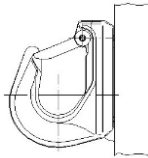

Weld-on hooks according to this THIELE company standard (TWN) are intended for lifting and handling loads and are primarily welded onto earth-moving machinery, e.g. shovels.

They are firmly connected to the load-bearing component by welding.

The weld-on hooks consist of a forged body and a spring-loaded safety latch.

The weld-on hooks are marked with working load limit, manufacturer's mark, CE mark and traceability code and are not painted.

They are certified by the German Employer's Liability Insurance Association for Wood and Metal in accordance with the "Principles for the testing and certification of attachment hooks for earth-moving machinery in lifting applications" (GS-OA 15-03).

Weld-on hooks may only be used

- within the permissible working load limit and attachment angle,
- within the permissible temperature limits,
- by trained and authorised persons,
- with mounted and functioning securing systems,
- with properly executed weld seams.

Weld-on hooks meet the requirements of Machinery Directive 2006/42/EC and have a design factor of 4 in relation to their working load limit (WLL).

THIELE weld-on hooks are designed to withstand 20 000 dynamic load cycles at maximum loading capacity. For higher workloads (e.g. multi-shift and automated operations) the loading capacity is to be reduced accordingly.

Eine Verwendung zum Zurren oder für den Personentransport ist nicht zulässig!

2 SAFETY NOTES

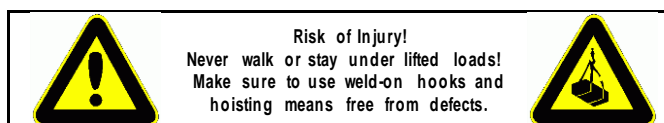

- Operators, fitters, and maintenance personnel must in particular observe the Operating Instructions of the used vehicle, vehicle assembly and hoisting means, documentations DGUV V 1, DGUV R 100-500 Chapter 2.8 and DGUV I 209-013 issued by the German Employers' Liability Insurance Association, as well as the standard specification DIN 15429.
- In the Federal Republic of Germany, the Operational Safety Ordinance (BetrSichV) has to be implemented and the Technical Rule for Industrial Safety TRBS 1201, in particular Annex 1, Chapter 2 "Special regulations for the use of working equipment for lifting loads" must be observed.
- Outside the Federal Republic of Germany the specific provisions issued locally in the country where the items are used must also be observed.
- Outside the Federal Republic of Germany the specific provisions issued locally in the country where the items are used must also be observed.
- The directions given in these Operating Instructions and specified documentations relating to safety, assembly, operation, inspection, and maintenance must be made available to the respective persons.
- Make sure these Operating Instructions are available in a place near the product during the time the equipment is used.
- Please contact the manufacturer if replacements are needed.
- **When performing work make sure to wear your personal protective equipment!**
- **Improper assembly and use may cause personal injury and/or damage to property.**
- Assembly and removal as well as inspection and maintenance must exclusively be carried out by skilled and authorized persons.
- Structural changes (e.g. bending, detachment of parts, drilling) are not permitted.

- Carry out a visual inspection before each use.
- **Operators must carry out a visual inspection and, if necessary, a functional test of the safety equipment before each use.**
- Never put to use worn-out, bent or damaged weld-on hooks or hoisting means.
- Only lift loads the mass of which is less than or equal to the working load limit of the weld-on hooks.
- Never expose weld-on hooks to loads exceeding the specified working load limits!
- Do not use force when mounting/positioning the weld-on hooks or hoisting means.
- Check that the load can withstand the forces including proof forces to be applied without deformation.
- Do not twist or knot the chains together.
- Avoid sharp edges. Use edge protectors or reduce the working load limit by 20 %.
- Only lift loads that are free to move and are not fastened or anchored.
- Do not apply bending stress to chain links and components.
- Shortening of chain sling legs is only permitted with approved shortening elements.
- Do not start lifting before you have made sure the load has been correctly attached.
- **Make sure no one including you (operator) is in the way of the moving load (hazard area).**
- During lifting/hoisting make sure your hands or other body parts do not come into contact with hoisting means.
- Remove hoisting means only by hand.
- Avoid impacts, e.g. due to abruptly lifting loads with chain in slack condition.
- Never move a suspended load over persons.
- Never cause suspended loads to swing.
- Always monitor a suspended load.
- Put the load only down in places/sites where it can be safely deposited.
- Do not catch hoisting means under the load.
- **Operation without functioning safety devices is not permitted.**
- In the event of doubts about the use, inspection, maintenance or similar things contact your safety officer or the manufacturer!

THIELE will not be responsible for damage caused through non-observance of the instructions, rules, standards and notes indicated!

Working under the influence of drugs, medications impairing the sense and/or alcohol (including residual alcohol) is strictly forbidden!

3 COMMISSIONING

Prior to using the components for the first time make sure that

- the components comply with the order and have not been damaged,
- test certificate, declaration of conformity and operating instructions are at hand,
- markings correspond with what is specified in the documentation,
- inspection deadlines and the qualified persons for examinations are determined,
- visibility and functional testing are carried out and documented,
- documentations are safely kept in an orderly manner.

Dispose of the packing in an environmentally compatible way according to local rules.

4 TECHNICAL DATA

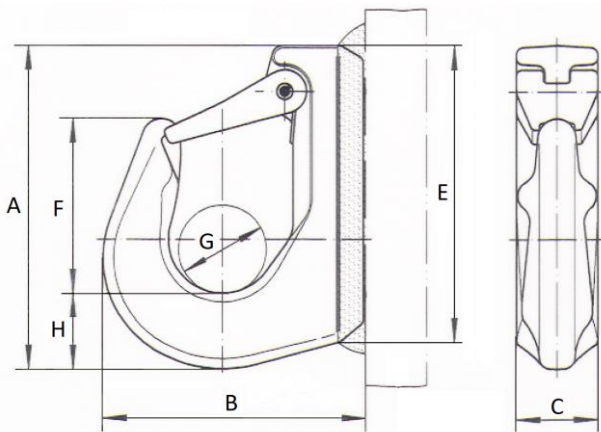

Nominal size / WLL	Article no.	Dimensions [mm]							Mass app. [kg]
		A	B	C	E	F	G	H	
1,12	F32751	94	77	24	85	51	26	24	0,5
2,0	F32752	120	97	30	107	65	33	28	1,0

The hook bodies are forged from the material S355.

5 WELDING INSTRUCTIONS

5.1 General

Material of weld-on hooks: S355
Material of weld-on joint: C22, S235, S355 or similar

The following general welding instructions must be observed:

- EN ISO 2560 Welding consumables – Covered electrodes for manual arc Welding of non-alloy and fine grain steel
- EN ISO 14341 Welding consumables – Wire electrodes and weld deposits for gas shield metal arc welding of non-alloy and fine grain steel
- ISO 3834-2 Quality requirements for fusion welding of metallic materials
- EN 1011-1, 2 Welding – recommendations for welding of metallic materials
- EN ISO 9606-1 Qualification testing of welders – fusion welding
- DVS 0702-1 / 0711 Factsheet - Requirements for operation and personnel

Welding is only permitted by trained and authorised personnel in accordance with the qualification according to EN ISO 9606.

Sketch:

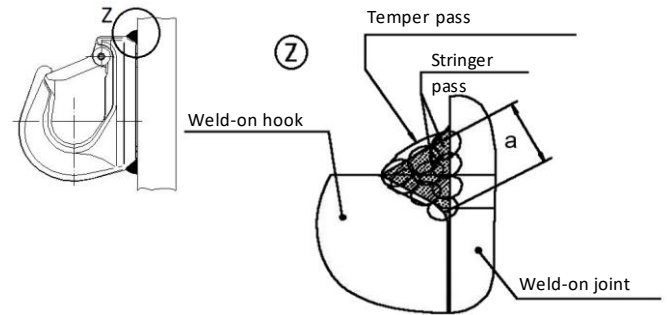

5.2 Preparation activities

Make sure that the welding surface is even, dry, free of rust, paint and impurities and suitable for welding (C-content $\leq 0.30\%$). Select the welding location in such a way that the forces to be applied can be absorbed by the component with sufficient safety and without deformations.

Nominal size / WLL [t]	Proof force MPF [kN]	Breaking force BF [kN]
1,12	27,5	43,9
2,0	49,0	78,5

5.3 Mounting conditions

Position the weld-on hooks in a way,

- that no danger areas (crushing points, shearing points, rotating parts) are created,
- that the forces to be applied can be absorbed by the component without deformations and that inadmissible stresses, e.g. due to off-centre load application, are avoided,
- that the forces to be applied can be absorbed with sufficient safety (at least 4 times in the major load direction, at least 2.5 times perpendicularly thereto) by the welding location for all intended load directions,
- that the hoisting means to be suspended in the weld-on hooks are not deflected by other components during subsequent operation,
- that the load is applied in the bottom of the hook and that the direction of loading is as parallel as possible to the longitudinal axis of the hook,
- that damage to hoisting means, e.g. by sharp edges, is avoided,
- that the weld-on hooks can be reached easily and without obstruction for attaching and detaching, even when set down,
- that an unintentional loosening of the hoisting means is avoided,
- that there are no obstructions caused by hooking or getting stuck, both during excavator and hoist operations.

Observe the welding instructions given.

The weld-on hooks must be inspected by a competent person after welding and before first use. This inspection must be documented.

5.4 Welding seam dimensions

Nominal size / WLL [t]	Min. welding seam thickness a [mm]	Welding seam cross-section [mm ²]
1,12	4	808
2,0	5	1 270

5.5 Welding process MAG

Welding process	Metal active gas welding (MAG) EN ISO 9606-1; No. 135		
Welding groove	see sketch		
Quality grade	Root run: EN ISO 5817 - C Final run: EN ISO 5817 - C		
Wire electrode	EN ISO 14341-A:2011: ISO 14341-A-G 46 4 M21 3Si1		
Welding position	EN ISO 9606-1: PA, PB, PF		
Preheating of parent metal	max. 150 °C		
Interpass temperature	≤ 400 °C		
Postweld heat treatment	400 °C - 20 °C tempering and / or apply quenching and tempering layer technology		
Pass	Root run	Final run	Temper pass
Wire electrode diameter	1 mm	1,2 mm	1 or 1,2 mm
Welding current (=)	130 - 200 A	135 - 290 A	See root run or stringer pass Note: The quench and temper layer must only be applied to the weld metal. Contact with the base metal must be avoided.
Electrode polarity	(= +)	(= +)	
Voltage	19 - 25 V	19 - 32 V	
Shielded gas ISO 14175; M21	10 - 12 l/min	12 - 14 l/min	
Kind of pass	Stringer pass	Stringer pass	

5.6 Manual welding process MMA

Welding process	Manual metal arc welding (MMA) EN ISO 9606-1; No. 111			
Welding groove	see sketch			
Quality grade	Root run: EN ISO 5817 - C Final run: EN ISO 5817 - C			
Wire electrode	EN ISO 2560 A:2010: min. ISO 2560-A-E 38 4 B 42 H5			
Welding position	EN ISO 9606-1: PA, PB, PF			
Preheating of parent metal	max. 150 °C			
Interpass temperature	≤ 400 °C			
Postweld heat treatment	400 °C - 20 °C tempering and / or apply quenching and tempering layer technology			
Pass	Root run	Final run	Alternative final run	Temper pass
Wire electrode diameter	2,5 mm	3,2 mm	4,0 mm	1 or 1,2 mm
Welding current (=)	80 - 110 A	100 - 140 A	130 - 180 A	See root run or stringer pass Note: The quench and temper layer must only be applied to the weld metal. Contact with the base metal must be avoided.
Electrode polarity	(= +)	(= +)	(= +)	
Voltage	-	-	-	
Shielded gas ISO 14175; M21	-	-	-	
Kind of pass	Stringer pass	Stringer pass	Stringer pass	

5.7 Others

- Minimum notched-bar impact strength values of ISO-V specimens $KV = 27 \text{ J}$ at -40 °C (z.B. S355J4G3 or S355NL, EN 10025).
- When selecting material grades other than those listed above please contact the base material and filler metal manufacturers for information.
- The responsible welding supervisor must make sure the welding current is correctly adjusted to suit the given welding position. The qualification must be in accordance with EN ISO 14731.
- Check the weld for cracks, inclusions and blowholes.

6 OPERATING

6.1 General

The safety latch must always engage form-fittingly with the tip of the hook to ensure a stable fit. Removal of the safety latch is not permitted.

Hoisting means must always be able to move freely in the hook jaw.

6.2 Temperature influence

The operating temperature range is -40 °C to $+200 \text{ °C}$.

After heating above the maximum temperature for use, the weld-on hooks must no longer be put into operation.

6.3 Load directions

Permissible load directions are shown in the following sketches:

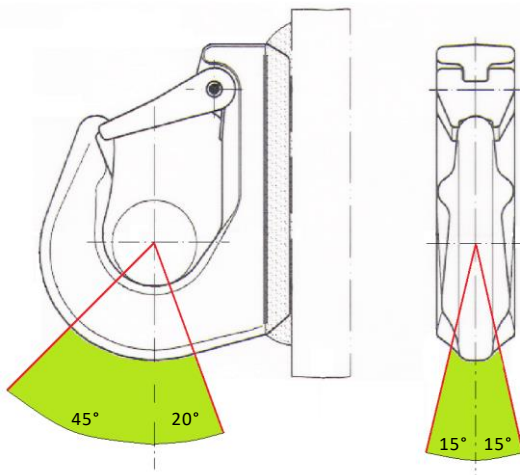

6.4 Environmental influence

Use in environments with acids, aggressive or corrosive chemicals or their fumes is not permitted.

Hot-dip galvanising or galvanic treatments are not permitted.

7 TESTING, MAINTENANCE, DISPOSAL

7.1 General

Inspections and maintenance must be arranged for by the Owner!

Inspection deadlines shall be determined by the Owner!

Inspections must be carried out and documented by competent persons regularly but at least once a year, or more frequently if the weld-on hooks are in heavy-duty service. After three years at the latest they must additionally be examined for cracks. A load test shall never be considered a substitute for this examination.

The results of the inspection shall be entered into a register (DGUVI 209-062 or DGUVI 209-063) to be prepared at first use. The register will show characteristic data as well as identity details.

Immediately stop using weld-on hooks that show the following defects:

- deformation, elongation or fracture,
- cuts, notches, cracks, incipient cracks, pinching,
- heavy wear in the hook jaw,
- missing or jamming safety latch,
- severe corrosion,
- missing or illegible identification/markings.

7.2 Maintenance

Maintenance work may only be carried out by trained and competent persons!

Minor cracks and notches can be removed by careful grinding, observing the maximum cross-section reduction of 10 % as well as the avoidance of notches.

Document all maintenance activities.

7.3 Changing the safety latch

Disassembly is carried out by driving out the dowel pin.

The assembly is done by positioning the spring and the safety latch and hammering in the thicker dowel pin. The thin dowel pin is then mounted. Make sure that its slot is positioned opposite the slot position of the thicker dowel pin. Check the proper function of the safety latch.

7.4 Inspection service

THIELE offers inspection, maintenance and repair services by trained and competent personnel.

7.5 Disposal

All components and accessories of steel taken out of service are to be scrapped in line with local regulations and provisions.

8 SPARE PARTS

Only use original spare parts.

Spare parts sets include safety latch, spring and dowel pin.

Nominal size / WLL [t]	Article no. set
1,12	F48730
2,0	F48732

9 STORAGE

Store weld-on hooks dry and protected against corrosion at temperatures between 0 °C and $+40 \text{ °C}$.

10 THIELE OPERATING AND MOUNTING INSTRUCTIONS

Current operating and assembly instructions are available as a PDF download on the THIELE homepage.



11 IMPRINT

THIELE GmbH & Co. KG

Werkstraße 3

58640 Iserlohn, Germany

Tel.: +49(0)2371/947-0

12 DECLARATION OF CONFORMITY

EC Declaration of conformity

acc. to Machinery Directive 2006/42/EG, Annex II A for a machine

THIELE GmbH & Co. KG herewith declares as manufacturer that

Weld-on hooks TWN 0850/1

are in compliance with the applicable provisions of the EU Machinery Directive 2006/42/EG.

The following harmonized standards have been observed:

- EN 12100 Safety of machinery – General principles for design – Risk assessment and risk reduction
- EN 1677-1 Components for lings - Safety

The following test principle of the employers' liability insurance association was applied:

- GS-OA 15-03 Principles for the testing and certification of attachment hooks for earth-moving machinery in lifting applications

This declaration/statement is not meant to warrant any product properties. Safety notes and instructions pertinent to the products must be observed.

Responsible for documentation

Rene Völz (Head of QA and EP), Tel.: +49(0)2371/947-541

Iserlohn, 6 April 2021

Dr. Michael Hartmann

(Managing director)

